

Impact Of Ethical Leadership on Work Engagement Via Perceived Organizational Politics; Moderating Role of Locus of Control

Aniqa Gill¹, Rizwan Qaiser Danish*², Muhammad Ramzan³

¹PhD Scholar, Institute of Business Administration, University of the Punjab, Lahore, Punjab, Pakistan.

^{2*}Associate Professor, Institute of Business Administration, University of the Punjab, Lahore, Punjab, Pakistan.

³Assistant Professor, Hailey College of Commerce, University of the Punjab, Lahore, Punjab, Pakistan.

Corresponding author: rqedanish@ibapu.edu.pk

Keywords: Ethical Leadership (EL), Perceived-Organizational Politics (POP), Work Engagement (WE), Locus of Control (LOC)

Article	History
Date of Submission:	
26-05-2023	
Date of Acceptance:	
28-06-2023	
Date of Publication:	
30-06-2023	

DOI No: 10.56976/rjsi.v5i2.114

Around 88 percent of the managers across the globe reported that politics, an endemic phenomenon exists in their organizations and around 87 percent employees are not completely engaged at work. Considering these emergent issues, the purpose of this paper is to examine the effect of ethical leadership on work engagement through perceived organizational politics, while considering locus of control as moderator in the association between perceived organizational politics and work engagement. This paper utilized a cross-sectional survey research design from 500 supervisor-supervisee dyads in both private and public service sectors of Lahore. Confirmatory factor analysis validated the dimensionality as well as reliability of the measurement model. Furthermore, the hypothesized associations were analyzed through two-staged structural equation modeling. Results revealed that perceived organizational politics mediates the association between ethical leadership and work engagement. In addition, locus of control was found to moderate the association between perceived organizational politics and work engagement. This paper did not establish any causal inferences between the constructs, therefore explanation pertinent to findings must be provided with great caution. This paper suggests practical inferences through mitigation of damaging effects of perceived organizational politics, a prevailing issue with deleterious outcomes and yet not addressed in Asian societies organizations. It emphasizes on organizations to recruit and train individuals with ethical behaviors that may help avoid employees' negative perceptions, resulting in increased employees' work engagement. This study extends the existent literature through examining perceived organizational politics (POP) as a mediating mechanism between ethical leadership and work engagement. It sheds light on the personality, politics as a psychological state with its outcomes, along with the cultural dimension for the first time in literature and explains the phenomena through which negative effects of (POP) are buffered by ethical leadership while in presence of individual differences that ameliorate or deteriorate the organizational outcomes. The theoretical framework is progressed through social learning theory and COR theory.

1. Introduction

Diverse workforce prevails in this global world, where organizations hold people from different back grounds and cultures (Martin et al., 2023). Although such organizations are less hierarchical and more egalitarian (Friedman, 2006), their battles and influential tactics remain to continue for limited resources, personal interests and other goals (Al-Abrow, 2022). Striving tactics for personal gains compel them to ignore the goals associated to the organization and all the stakeholders. When people shape their behaviors strategically in order to get either short or long-term personal interests, organizational politics are most likely to occur (Chen *et al.*, 2023). Perceived organizational politics (POP) is an aboriginal phenomenon and 88 percent of managers across the globe report that it exists in their organizations (Buchanan, 2008). It is about the satisfaction of personal-interests and fulfilment of individual needs at the expense of others. Organizational politics is referred to “individuals’ actions which are aimed at optimizing their personal interests without taking into consideration the well-being of neither the organization nor others (Kacmar & Baron, 1999).

According to Ferris (1991), POP are self-interesting behaviors displayed by influential members of the organization pertinent to manipulating the organizational rules and regulations to help some people at someone else’s expense. POP being dysfunctional, dilutes organizational level performance and its outcomes causing competitive disadvantages (David, et al. 2023: Kapoutsis et al., 2011). It redounds negatively with varied work outcomes i.e., negligent behaviors, task performance, affective commitment, creates moods depression, stress and job anxiety (Vigoda-Gadot, 2014). Ambiguity in policies, competition in environment, and scarce resources give rise to such political behaviors (Rosander & Kadefors, 2023). When rules and regulations are not clear, people tend to create their own rules or bring modifications to the existant rules in order to get the position they desired for in the organization. Ambiguous policies emanate flawed decision-making (Haq et al., 2018). The irrational decision-making motivates people to make decisions that best suit their interests, which leads to the engagement of the political behavior (Cropanzano et al., 1997). In Pakistan, public sector organizations best represent the case where people take advantage of the flexibility of rules and temper them for their personal interests.

Organizations which are being clouded by ambiguity in rules and policies require leaders who can clearly communicate ethics and can set and uphold high ethical standards. The social learning perspective pertinent to ethical leadership suggests that leader may influence on follower’s ethical conduct through modeling. Role modeling may help followers to learn what behaviors are rewarded or punished (Brown, 2005). Consequently, employees may adopt new ethical ways of living as well as working, considering that their ethical leader lives and works by appreciating the right and appropriate (Trevino et al., 2003). Moreover, ethical leadership encourages fair competition among subordinates, so those who strive for self-interests at their colleagues’ expense may get exposed to others and may lose their leader’s confidence (Banerjee et al., 2023). While those who have learned ethical preferences of the organization either through direct learning or vicarious learning may remain abstained from getting involved into political behaviors, which may reduce politics in the organization. Moreover, individual

differences may have varied perceptions of the politics. So, employees with internal locus of control (i.e., skills, perseverance) may experience a strong buffering effect of ethical leadership on negative effects of perceived organizational politics as compared to the externals (i.e., external factors, divine intervention, powerful others) (Virga & Balan, 2023).

This study contributes to the existent literature in many folds. First, drawn on the social learning theory, it establishes a model which positions POP as a mediating mechanism through which ethical leadership affects work engagement. Researcher posits that there exists a negative association between the ethical leadership and POP, which proposes that high levels of ethical leadership may result in lowered levels of POP and also there exists a negative association between POP and work engagement which is the outcome variable. Primarily, not even a single study sight sees these dynamic linkages between EL, POP, WE and LOC. Second, drawn on the COR theory, which states that individual differences either accentuate or ameliorate the perceptions about the politics, inclusion of locus of control which is referred “to the extent to which individuals accredit the causes of events that occur to them to either internal (i.e., skills, perseverance, and efforts) or external factor (i.e., powerful others, divine intervention, and opportunities)”, to enhance the apprehension of how ethical leadership impacts employees with entire mediating effects of POP, while in comparison to exclusion of locus of control (LOC) to un-reveal the inherent complexities of ethical leadership effects in its entire self with increased POP. This study proposes useful inferences for leaders on how to dilute the deleterious effects of POP by recruiting and training individuals with ethical behaviors and internal LOC. Individuals with ethical behaviors may reduce the POP, and internals are at their predisposition to perceive their work environment in a positive manner and are better equipped with resources, and are adept to handle stressful work conditions compared to the externals who blame external factors for all the negative outcomes.

Drawing on the social learning theory this study establishes a model to explain how ethical leadership can make workplaces free of political behaviors (Brown & Trevino, 2006). The main extract of the social learning theory is that individuals learn by giving attention to behaviors of role models that are credible and attractive to them and eventually emulate those behaviors. Furthermore, in organizations where ethical values are ambiguous, leaders through their clear communications pertinent to ethics may uphold high standards. Upholding these standards require them to punish unethical behaviors as well as rewarding the ethical ones. Contrarily, if leaders behave unethically, such an environment is cultivated where politics seems dominant. Under such circumstances, mapping the rewards to the performance may become impossible as leaders may circumvent rules and regulations are at their own discretion and political interests. Such unethical conduct by leaders gives message to the followers that political behaviors are appreciated in the organization.

2. Literature Review

2.1 Ethical leadership and perceived organizational politics

Over the decades the account for economic downturn in the organizations across the globe, is being plagued by the unethical leadership. Consequently, both the management and

scholars have demonstrated strong inclination in fostering ethical behaviors inside the organizations. It has been exhibited through great emphasis on ethics at the higher levels of education as well as in code of ethics by corporate (Avey et al., 2011). Ethical leadership refers to the demonstration of behaviors that are aligned with the appropriate norms and is reflected in the leader's actions and associations (Brown et al., 2005). Recent, research work has highlighted that there exists the paucity in studies that explain the mechanism of how ethical leadership influences the organizational outcomes (Mayer et al., 2010). Most literature focuses on organizational outcomes such as job satisfaction, withdrawal intention, and affective commitment (Agarwal, 2014). Although such outcomes show relevancy to organizational effectiveness, it is essential to examine POPS effects on some critical organizational outcomes i.e., work engagement and innovative behavior which may provide competitive advantage to the organization (Parzefall & Hakanen, 2010). Kacmar et al. (2013), proposed organizational politics as the mediating mechanism between the ethical leadership-outcomes association. Organizational politics is defined as "a social influence under which individuals act strategically with the goal to maximize their self-interests without taking into consideration the well-being of all stakeholders or even the organization". While a few researchers have discussed politics in a favorable light and mentioned it to be an effective way to get the work done (Pfeffer, 1992). Others have emphasized the negative facet of politics that examine various negative organizational outcomes (Miller et al. 2008). Negative political perceptions come into existence when employees perceive that their organization is abundant with disruptive and illegal pursuits that accelerate someone else's goals rather than the organization while leaving them not benefited (Ferris & Hochwarter, 2011). Such political behaviors include vandalizing colleagues' efforts, excessive cajolement from one's boss right before the evaluation, and not registering others' contributions (Rosen et al., 2009). Moreover, Rosen & Hochwarter (2014), included intended manipulation, infidelity, hiding useful information and falsifying as political behaviors. Given the negative tone and bad intent of politics, it is not surprising why employees act in a negative manner i.e., suffering high anxiety as well as stress, dissatisfaction, and withdrawal intention, and demonstration of reduced work engagement and performance.

Social learning theory (Bandura, 1977), states that people learn by paying attention on their role models and they then tend to evaluate the appropriate behaviors, attitudes and norms to display and also by observing the positive or negative consequences that come after them. Models' effectiveness to influence their followers depends on their credibility and legitimacy (Brown et al., 2005). As per SLT, employees may learn in two distinct pathways. First, by experiencing the direct consequences. Second, by not experiencing the direct consequences. For instance; an employee may observe a colleague who is awarded for enforcing intense cost cutting techniques that caused other employees at risk. Employee has learned that the company prefers profits over safety of employees and therefore may implement further cost cutting techniques. In the organizations, where manager's violations to code of ethics get consistently unpunished, may lead to high levels of political behaviors. Given that managers may learn when they can use political behavior through direct as well as indirect consequences. The study's model suggests that individual, organizational environment and organizational factors

(i.e., work autonomy, span of control) contribute to organizational politics, which consequently influence work attitudes as well as behaviors. However, in presence of ethical leadership, POPS influenced is mitigated. Variation in influence may be visualized due to individual differences political perceptions.

Figure No 1: Conceptual Model

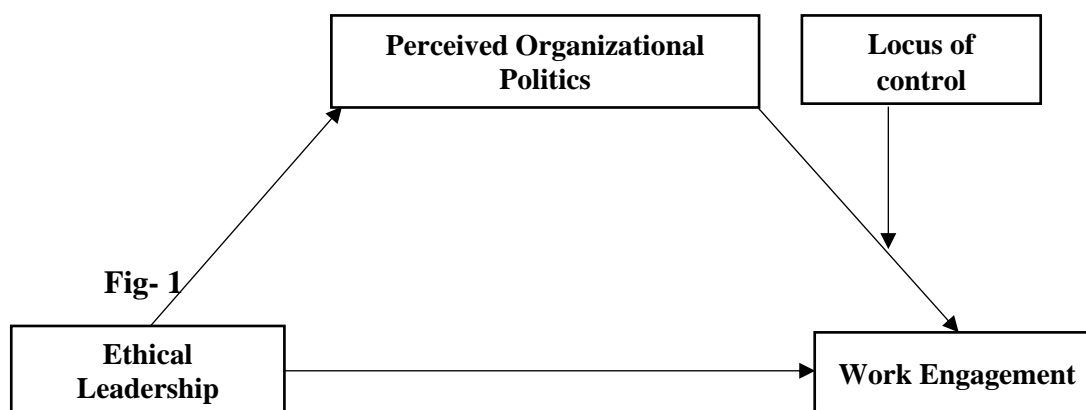

This study contends that ethical leadership should minimize POP. On the contrary, when organization is guided by unethical behaviors, decision-making benefits only managers over others and the organization. Employees eventually generate judgments related to the ethicality of their managers by measuring their behaviors with what is ethically acceptable (Tyler, 1986). Employees may interpret these self-interested behaviors as political and feel at ease to make decision-making on the political grounds instead of adopting appropriate norms and values. Therefore, based on the social learning theory and other integrated streamlines it is hypothesized that

H1. Ethical leadership is negatively associated with perceived organizational politics (POP).

2.2 Ethical leadership and work engagement

Ethical leadership refers to displaying of conduct which is consistent to appropriate norms, behaviors and values through personal acts and interpersonal associations, and promoting such conduct through two-sided interaction, reinforcement as well as decision-making to the followers (Brown *et al.*, 2005).

Work engagement refers to a positive, fulfilling work-related state of mind which is attributed to vigor, absorption and dedication (Schaufeli *et al.*, 2006). The vigor component refers to how much an individual is willing to invest efforts into the work. The dimension of dedication refers to feeling challenged, proud and meaningful at work. While absorption refers to the characteristic of being fully immersed, and engaged at work.

According to social learning theory, there exist two paths through which leaders may have their influence on their subordinates. First is where managers exhibit ethical behaviors and thus employees learn the organization’s ethical preferences. Second path is where employees learn organization’s ethical preferences through their personal experiences. When employees see their manager promoting ethical standards, fairness in procedures, two-sided

communication, participation in making decisions fair awards and promotions then they are not threatened of losing their resources (Den Hartog, 2008). Consequently, they make use of their resources to their full potential rather than conserving them, which leads to the increased work engagement (Loi *et al.*, 2012). Moreover, ethical leadership encompasses characteristics of fairness and trust (Brown *et al.*, 2005), which treat employees with fair awards that lead to motivate employees to pay back to the organization through increased work engagement (Saks, 2006). Ethical leadership provides employees with great autonomy and control over job resources and opportunities for training and development (Seibert *et al.*, 2011), whereas, both the autonomy and opportunities for development are major drivers of engagement at work (Markos & Sridevi, 2010). Based on the discussed logical lines it is hypothesized that

H2. Ethical leadership is positively associated with work engagement.

2.3 Perceived organizational politics and work engagement

Work engagement, was first defined by Kahn (1990) to express the holistic self who expresses complete devotion into cognitive as well as emotional labors (Rich *et al.*, 2010). Drawn on Kahn's work Schaufeli *et al.* (2002), presented work engagement as a positive, satisfying work associated state of mind which has the characteristics of vigor, dedication and absorption. According to Byrne *et al.* (2016), work engagement precedes with perceptions of psychologically meaningful, safe and available. Meaningfulness is driven from aim, inclusive inter-relationships and autonomy of work. Whereas, safety encompasses the perception that work employment of their preferred self will not lead to criticism, or any other negative consequences (Kahn, 1990). A wide range of workplace components may influence psychological safety i.e., supervisor's or colleagues' interrelationships and importantly, "organizational politics". Lastly, psychological availability also requires employees to remain focused without intrusions and distractions. The three conditions serve as the basis of influencing the decision about whether or not to stay engaged at work (Rosen *et al.*, 2017). Given that if employees see that their work is not meaningful and they are not psychology safe, available or getting victimized by organizational politics, they will not be engaged at work. Moreover, according to Byrne *et al.* (2016), perceived organizational politics can result in reduced work engagement. Deleterious effects associated with perceived organizational politics on work-related outcomes such as stress, withdrawal intentions, and organizational commitment have been well-examined through theory as well as research (Vigoda-Gadot & Talmud, 2010). Whereas, a very little light has been shed on how organizational politics effects on work engagement, a conception increasingly acknowledged as significant to organizational competitive advantage (Barrick *et al.*, 2015). According to Landells and Al-Brecht (2019), there exists a negative association between political perceptions and work engagement.

Drawn on social learning theory, this study argues that in case the organization is clouded by politics, employees learn the unethical behaviors such as non-sanctioned tactics from their supervisors (Zanzi & O'Neil, 2001). They then tend to imitate them by seeing the consequences of wrong get unpunished consistently. Employees may develop resistance against their supervisors when they try to influence them which may result in disengagement. When supervisor manipulates, distorts facts, employees get disengaged as a reaction. They may

repeat such resistance by seeing such attempts influential for not getting punished in political environment as well as finding a temporary relief by disengaging as a coping mechanism (Byrne, 2015). Thus, on the basis of limited findings, and social learning theory it is hypothesized:

H3: Perceived organizational politics is negatively associated to work engagement.

2.4 Moderating Role of Locus of Control

The earlier research suggests that politics is not acknowledged globally as a negative or threatened work aspect (Fedor et al., 2008). It all depends on the ambiguity lying inside the political environment which allows varied interpretation by the individuals. A strong type of control gets associated with the negative association between the POPS and work outcomes. At its prevailing tendency, LOC presents the level to which people associate causes about what happens to them i.e., internals (perseverance, abilities, and efforts), or to externals (powerful others, opportunities, and determined luck). People with internal LOC are at the disposition of perceiving their environments at work in a positive manner and are expert at assessing and reacting to the stressful work conditions. They acknowledge stress at their daily routine as controllable and follow their work and personal pursuits even in presence of adversities (Yukl & Latham, 1978). On the other hand, people with external LOC, are at the disposition of acknowledging their environments at work in a negative manner. They realize the situations at work as threatening and accuse external factors and others for the consequences (Judge et al., 2003). They associate negative consequences to others i.e., associations with colleagues or rivalry in business. Internals maintain better associations with their colleagues and supervisors and are expected to get involved in problem-focused strategy for coping such as designing and implementing plans accordingly, and asking for social support in order to minimize stress.

In spite of the significance, LOC has remained less explored in research work. Most of the prior literary work has used LOC as a mediator or predictor for instance; Chiang (2019), reported its mediator role between emotional stability and pro-environmental behavior. While, Zainun (2020), noted the predicting role of LOC on ethical leadership. There is hardly any study which has examined LOC as a moderator with such predicting and mediating mechanisms other than this study (with exception for, Agarwal, 2014). This study extends LOC literature by evaluating the trickling effect of ethical leadership on such associations and mechanisms. Drawn on the COR theory which states that employees devote sustained effort to acquire, maintain and preserve valued resources whenever they realize a real or threat to lose resources (Hobfoll, 1989), this study explores the effect of LOC on the associations between POPS and work engagement. As per COR theory, political perception of employees is either accentuated or ameliorated by individual differences (Witt et al., 2002). Given the reason that internals are better equipped with the personal resources as well as social capital i.e., better inter-linkages, they show more commitment in pursuing organizational goals even with obstacles compared to the externals. Based on COR theory and above discussed logical lines it is hypothesized that:

H4: LOC moderates the negative association between POPS and work engagement such that the negative association is stronger for externals and weaker for internals.

2.5 Ethical Leadership, Perceived Organizational Politics and Work Engagement

Work engagement may lead to a psychological state that is positive in nature and allows employees to focus on and prioritize the positive job aspects (Lambert et al., 2018). Researchers emphasize managers to shed light on all the negative tendencies that might become the reason for the derailment of organizational productivity with respect to work attitudes (George et al., 2020). In this respect, an unethical work environment leads to lower productivity which is coupled with work engagement (Shah et al., 2020). Emerging body of research has indicated that POP is negatively associated to individual as well as organizational outcomes (Malik et al., 2018). Work engagement is reported to have influence of job and personal resources, which are positive in nature (Schaufeli et al., 2008). Job resources are referred to as physical, or organizational work aspects that may help in reducing relevant physiological as well as psychological costs, achieving organizational goals, igniting personal growth and development (Baker & Demerouti, 2008). Some important job resources are social support and autonomy (Schaufeli et al., 2008). Whereas, personal resources are self-related aspects that are related to resilience, and abilities to control and influence their environments (Hobfoll, 2003).

Literature, has evidenced that personal resources facilitate growth as well as development (De Clercq, 2020). Henceforth, such dependence of resources on work engagement requires employees to have high work engagement for the acquisition of these resources. However, the contemporary world of work faces 87 percent of its employees who are not completely engaged at their work (Islam et al. 2018), and are redundant on resources which are essential for organizational effectiveness. Moreover, organizational politics exist globally that may further diminish those resources. Employees, therefore they need to learn those behaviors that not only help prevent these limited resources from diminishing but also may help on how to use them effectively and increase them even in adversaries. Social learning theory states that employees may learn such behaviors through modelling i.e., learning, imitating and identifying. Learning occurs through either by direct experience or through vicarious experience which is the observation of others and their consequences. Such learning mechanism is of extreme importance where behavioral targeting highlights ethical conduct to be problematic.

Role modelling may help employees to learn what behavior is rewarded or punished. Leaders are most likely the modelling source. When leaders are expected to be ethical, they must have traits of credibility and legitimacy, because the ethical pronouncements of these leaders can make employees skeptical about them, in special inside the scandalous work environment (Brown et al., 2005). Moreover, social learning theory emphasizes that both rewards and punishments help in learning in the predicted manner (Bandura, 1986), thus employees learn that what behaviors of their leaders resulted in awards and what behaviors caused punishments. Such learning makes them afraid of getting involved in the unethical behaviors which emanate negative political perceptions. Ethical leaders may reduce organizational politics to a certain extent through the imposition and praise of virtues i.e.,

integrity, perseverance, loyalty, reliability via modeling. Employees perceiving politics who cannot withstand it, acknowledge threat to tranquility, prestige and well-being as employees who benefit by engaging in political games unfairly, hold others back to be in the competition by disqualifying them depending to their power inside the organization (Miller et al., 2000). As ethical leaders enhance moral values and fair systems, the benefits obtained through political manipulations by some employees may be disfavored, while fair competition will be appreciated by them resulting in a negative association being anticipated between ethical leadership and organizational politics (Basar et al., 2018). Moreover, when employees will learn that their leader is fair and credible, their perception about losing their resources may change into trust and they may get engaged at work by utilizing their resources to their full potential rather than conserving them, resulting in increased work engagement. Byrne et al. (2017), have construed that organizational politics may cause decreased work engagement. Therefore, consistent with the above discussed arguments and social learning theory it is hypothesized that:

H5: Perceived organizational politics mediates the association between the ethical leadership and work engagement.

3. Methods

3.1 Participants and Procedures

To investigate the effects of ethical leadership on POP- work engagement, in light of locus of control as a moderator, this study collected data through cross-sectional survey of employees who were working in services sector of Punjab province of Pakistan. It includes the diverse workforce of PC hotel, Lahore. Therefore, Punjab service sector employees were the study's target population. The services industry was investigated through this study, as it contributes economically to an approximate of 61.2% of Pakistan's total GDP (O'Neil, 2022) and a main source of employment (Javed, 2019), absorbing 38.6% of entire labor force. According to State Bank of Pakistan, the services sector exports in 2019 were approximately \$5781 million. Therefore, it plays a vital role in the growth trajectory of this developing nation. On the other hand, the study sheds light on the bitter reality that in Pakistan, approximately 2.6 million service sector employees in the country are being visualized as corrupt, exploitive, and involved in unethical bureaucratic procedures (Abbas & Awan, 2017). Moreover, Pakistan is a country with high power distance and accepts unequal power distribution to the higher levels compared to western countries. So, individuals in authority can manipulate organizational rules and policies for their personal interests in the absence of strict checks and balances, leading to high POP which may influence adversely on work engagement of employees unless being led by ethical behaviors and internal locus of control rather than externals.

This study used convenience sampling as the list of all the respondents to this study was not accessible. However, according to Pakistan Bureau of Statistics, 38% of total employees work in the services sector. Moreover, item response theory with the criterion of 20 responses for each question of the scale was applied (i.e., $31 \times 20 = 620$), henceforth study's sample was 620 (Islam et al., 2019). All the measures used in the study were progressed from

English, whereas respondents' native language was Urdu. Therefore, questionnaires were first translated into Urdu and then their face validity was assured by experts. Study's respondents were approached with equal number of questionnaires by their HR manager who provided explanation for the better understanding of the potential participants about the survey. A letter of consent was also obtained for participation of survey from the HR managers. The questionnaires were administered in two waves, whereby in the first wave, supervisees were requested to provide their responses about demographics, leadership (i.e., ethical leadership), their perceptions about organizational politics, and locus of control. In the second wave, supervisees' work engagement was reported by their supervisors. A total of 620 questionnaires were distributed, whereas 415 were received and 15 were considered redundant, only 400 were utilized for final analysis. Most of the study's respondents were female (217, 54.3%), and majority were of young age (i.e., 21-25 years, 56.3%), were having a bachelor degree (i.e., 217, 67.5%) and had work experience (221, 55.3%).

3.2 Measures

The study adopted the questionnaires from prior researches which have been declared valid and reliable. Employees' responses were recorded on 5-point Likert scale that ranged from 1= "strongly disagree" to 5 = "strongly agree" for the measurement of its constructs. Ethical Leadership: The study used Brown et al.'s (2005) scale for measuring ethical leadership. An example item is: "Disciplines employees who violate ethical standards". Scale's Cronbach alpha value was 0.98. Perceived Organizational Politics: Employees' perceptions about organizational politics were analyzed using Kacmar and Carlson (1997) scale. A sample item is: "People in this organization attempt to build themselves up by tearing others down". This scale's Cronbach Alpha value was recorded as 0.85. Work Engagement: Employees' work engagement was measured using Schaufeli et al.'s (2006) scale which comprised of nine items. An example item is: "At my job, I feel strong and vigorous". Cronbach Alpha value of this scale was noted as 0.97. Locus of Control: Levenson (1974) scale was used to analyze employees' locus of control. A sample item is: "When I get what I want, it's usually because I worked hard for it". Cronbach Alpha value of this scale was noted as 0.98.

4. Results

The data were analyzed in AMOS through SEM after consideration to assumptions i.e., missing values, outliers, multicollinearity and normality to ensure model fitness for hypotheses testing. Missing values were assessed in adherence to Sekaran (2003) call, where all the responses having missing values greater than 15% to be considered redundant was applied. Whereas, no missing values were detected in the data and the rationale for that may be because the survey were administered in person and respondents were requested to complete responses when realizing any missing value on receipt. Moreover, outliers from the data were evaluated through Mahalanobis distance procedure at ($p < 0.00$) in adherence to Kline (2005) recommendations and as a result 15 outliers were deleted from the data. Data normality was assessed through the cut off values of skewness ± 1 and kurtosis ± 3 (Byrne, 2010) and results showed that data were normally distributed. Collinearity was assessed based on the bivariate correlations and the values in all variables lied below 0.85 which resulted in their acceptance

for further analysis (Tabachnick & Fidell, 2007). Finally, 400 responses in all were used for Structural Equation Modelling for hypothesis testing.

In order to tackle common method bias, this study not only collected data from both private and public organizations but also applied Harmon’s single factor test to detect the presence of any CMB. However, the results revealed that single factor variance extraction was 46% which was acceptable as per the criterion of maximum 50% (Podsakoff *et al.*, 2003). Therefore, results did not find CMB as problematic. Adhering to Anderson and Gerbing (1988) instructions, two-staged Structural Equation Modelling was applied. Wherein the first stage, Confirmatory Factor Analysis (CFA) was conducted since the study adopted questionnaire as of previous researches. Model fit indices were examined in adherence to Hair *et al.* (2010) and the results in Table-1 indicates that model provided a good fit through permissible model fit indices i.e., $\chi^2/df = 2.488$, NFI = 0.95, AGFI = 0.85, CFI = 0.97, GFI = 0.85 and RMSEA = 0.06 with the factor loading values were all greater than the benchmark of 0.50 (Fornell & Larcker, 1981). A few error term values of the same latent factor were found high and therefore they were covaried which further improved the values of model fit indices i.e., ($\chi^2/df = 1.746$, NFI = 0.97, AGFI = 0.89, CFI = 0.99, GFI = 0.91, and RMSEA = 0.04).

Table No1: Model Fitness Ratios

Fit Index	χ^2/df	NFI	AGFI	CFI	GFI	RMSEA
Desired Values	≤ 3.00	≥ 0.90	≥ 0.90	≥ 0.90	≥ 0.90	≤ 0.08
Initial CFA	2.488	0.95	0.85	0.97	0.85	0.061
Modified CFA	1.746	0.97	0.89	0.99	0.91	0.04

Notes: Chi-Square/degree of freedom; χ^2/df ; Normal Fit Index; NFI, Adjusted goodness of fit index, AGFI, Comparative fit index; CFI, Root mean square error of approximation; RMSEA.

Table No 2: Correlation Analysis

Variables	Mean	SD	α	1	2	3	4
1-EL	3.04	1.35	0.98	1			
2-POP	3.09	0.99	0.85	-.916**	1		
3-WE	3.24	1.22	0.97	.402**	.348**	1	
4-LOC	3.22	1.62	0.98	.748**	-.669**	.744**	1

Notes: SD = Standard Deviation, EL = Ethical Leadership, POP = Perceived Organizational Politics, WE = Work Engagement, LOC = Locus of Control where *p < 0. 05, **p < 0. 01.

Study’s convergent and divergent validity was evaluated through examining the values of composite reliability (CR) and Average variance extracted (AVE). According to Byrne (2010), CR and AVE values were greater than 0.60 and 0.50 respectively. In addition, Cronbach Alpha values for all the scales were greater than 0.70 (Islam *et al.*, 2019).

Moreover, descriptive analysis results are given in Table 2. Mean values of EL, POP, WE, and LOC were 3.04, 3.09, 3.24, and 3.22 respectively. Pearson correlation indicated that ethical leadership was negatively correlated to POP ($r = -.916, p < 0.01$), and positively correlated with both WE ($r = .402, p < 0.01$), and LOC ($r = .748, p < 0.01$).

Figure No 2: Measurement Model

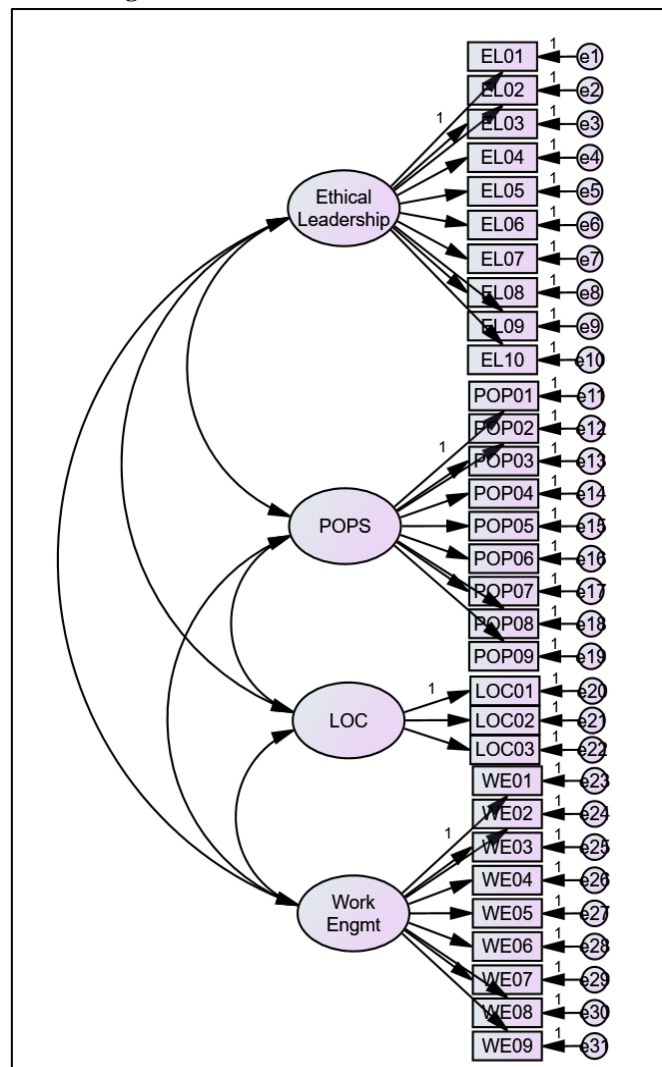
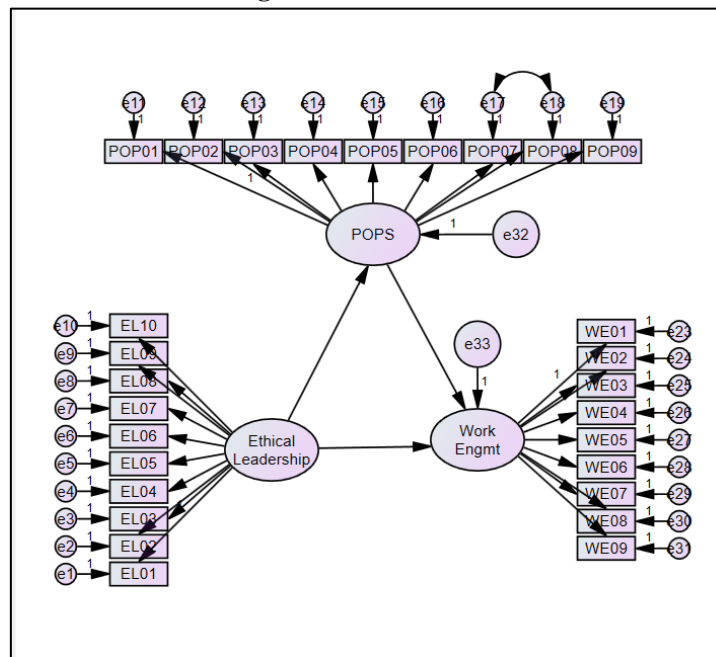

Figure No 3: Mediational Model



4.1 Hypotheses Testing

The results of path coefficients indicated a negative and significant impact of EL on POP ($\beta = -0.673, p < 0.01$), a positive and significant impact on WE ($\beta = .672, p < 0.01$), whereas a negative and significant impact of POP on WE ($\beta = -.818$). Henceforth, H1, H2, and H3 were supported. Bootstrapping method was applied to examine the direct and indirect effects of the theoretical model in SEM. Bollen and Stine Bootstraps where $N = 3000$ and confidence interval for bias correction BCCI at 95% were used. Table shows the direct effect of EL on WE without mediator ($\beta = 0.996, p < 0.001$), direct effect of EL on WE with mediator ($\beta = 1.399, p < 0.001$) while indirect effect of EL on WE with mediator ($\beta = -.622, p < 0.001$). Since, both direct and indirect beta values with mediator were significant, therefore there existed partial mediation of POP between EL and WE. Henceforth, H4 was supported. In order to examine the moderation effects of LOC, composite variables were created using factor scores, and later all the constructs were standardized. Moreover, an interactional term was generated and model was tested for fitness. The results revealed that the unstandardized weights of POP ($\beta = -.663, p < 0.01$), LOC ($\beta = .271, p < 0.01$). Moreover, interactional term for (POP*LOC) ($\beta = 0.06, p < 0.05$). Since, the interactional term was significant, therefore there exists moderation of LOC between POP and WE. To better understand the moderation effect, the interaction pattern was plotted using Mod graph and the pattern indicated that perceived organizational politics is more negatively associated to work engagement when locus of control is low and vice versa. Henceforth, H5 was supported as well.

Table No 3: Direct Effects

Path	Estimate	S. E.	Significance Level
EL → POP	-0.673	0.015	***
EL → WE	0.672	0.030	***
POP → WE	-0.818	0.046	***

Table No 3: Mediation Effects

Hypotheses	Dβwithout Mediation	Dβwith mediation	Indirect Beta	Mediation Observed
EL→POP→WE	.996***	1.399***	-.622***	Partial Mediation

Notes: *** $p < 0.001$

Fig No 4: Moderating effects

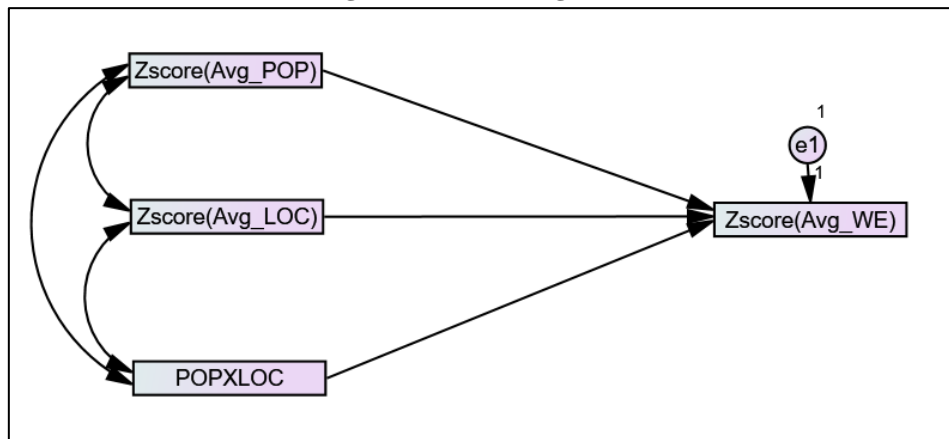
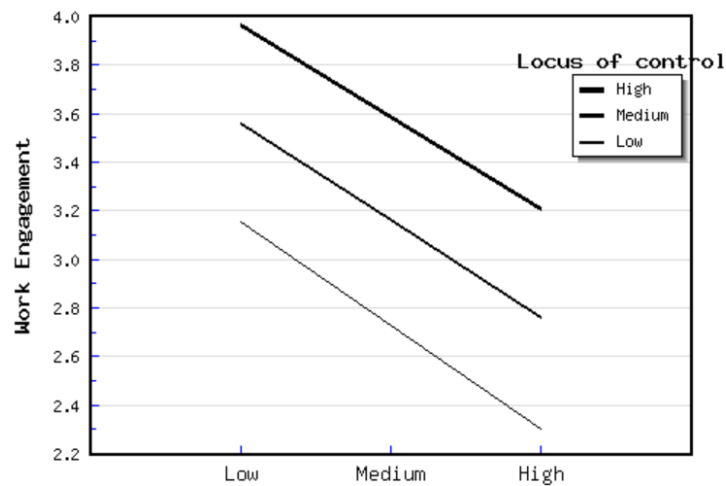

Fig No 4: Locus of Control as moderator



4.2 Discussion

The rise of knowledgeable economies across the globe, lack of engagement and increasing human turnover has set forth the leadership style at the very front of the contemporary agenda of business and management. The present study underpins the negative organizational politics and declares it as an obstacle to meet this agenda through investigation of direct and interactive effects with work engagement, locus of control and ethical leadership.

The study emphasizes that employee's POP is the subjective evaluation about the prevalence of egocentric work environment and it may affect the exchange relationship that exist between employee and the organization. Individuals work with the expectations to receive monetary or psychological rewards i.e., recognition or gratitude which is associated with the performance. However, their sensing the prevailing organizational politics compel them to be more concerned of receiving the rewards that may bring their power and not depend on their objective performance (Chang, et al., 2009). Although leadership style such as ethical may help to mitigate the negative effects of POP but it may get itself affected by the empowering pollution of the political environment. This study's results indicate that ethical leadership in presence of POP's mediation route may not be as much positively influential as it is otherwise, unless employees have internal locus of control i.e., skills and abilities to manage adversaries effectively.

5. Conclusion

The basic purpose of this study was to investigate how ethical leadership influence the work engagement. Although there are multiple studies that investigated this linear relationship but the processes through which work engagement can be predicted, specifically perceptions of politics as mediator have been rarely studied phenomenon. Moreover, the moderating role of locus of control was considered to buffer this relationship. We found the evidence for the support of our hypotheses and this study is an important effort to create a healthy and ethical environment where employees can work with great zeal and enthusiasm.

5.1 Theoretical Implications

Theoretical foundations and literary work in ethical leadership field suggest the linkages between the behavioral outcomes such as work engagement, organizational commitment, physical and psychological stress, towards employee and the organization (Ahmad *et al.* 2019). Moreover, the existent research on POP finds fragmentation, isolation and inconclusion on mechanisms of its actual working, thus leaves a room for future investigation in organizational studies and human resource practices. The present study fills the gap by identifying the antecedents, predictors, new explanatory mechanism of its influence on employee's work engagement using strong theoretical footings and statistical evidences. The current study contributes to existent literature in multiple ways. First it is conducted in services sector which is highly diversified and contributes more than half approximately 54% to the total GDP of Pakistan. However, research in services has always faced remarkable ignorance leading to deteriorated and dismantling workplace systems, corruption, and anxiety. Second, drawing on Social-learning theory, this study introduces locus of control as a moderating variable which increases the apprehension of how ethical leadership effects hospitality workers with complete mediating effects of POP while compare to exclusion of locus of control. Such associations in a unique sequence have hardly been carried out in the past.

5.2 Practical Implications

This study investigated the moderation of locus of control in the negative organizational politics and work engagement. Since, employees with internal locus of control are expected to respond constructively in uncertain and ambiguous situations, given their strong believe in their inner strengths, and abilities, they are less likely to be affected by negative politics. So, policy makers and managers should hire individuals with internal locus of control to handle unfavorable situations. Organizations are advised to investigate the hierarchical structure and phenomenon that precedes human turnover on realizing political symptoms at workplace. Employees should be equipped with abundant resources to cope with adversaries. There should be a system for checks and balances that may ensure that leaders matter ethically as much as their subordinates. Therefore, any supervisor displaying political behavior should be strictly held responsible and penalized for such behavior and the outcomes, and his/her say in decision-making process should be adjourned immediately on site. Under such circumstances, organizations should manifest training programs for managers that emphasize on positive leadership and necessitate them with psychological counselling to breathe out their stress in order to keep good associations with employees.

Despite of its theoretical and practical implications, this study has several limitations. Owing to practical difficulties, this study did not establish longitudinal research design that is more effective method that may investigate antecedents and mechanisms of individual-organizational outcomes. This study should be retained in some different cultural context to increase its generalizability. Future research may combine the study's variables along with GHRM or some scientific levelled constructs to widen its scope.

6. References

- AL-Abrow, H. A. (2022). The effect of perceived organisational politics on organisational silence through organisational cynicism: Moderator role of perceived support. *Journal of Management & Organization*, 28(4), 754-773.
- Asrar-ul-Haq, M., Ali, H. Y., Anwar, S., Iqbal, A., Iqbal, M. B., Suleman, N., ... & Haris-ul-Mahasbi, M. (2019). Impact of organizational politics on employee work outcomes in higher education institutions of Pakistan: Moderating role of social capital. *South Asian Journal of Business Studies*, 8(2), 185-200.
- Bakker, A. & Demerouti, E. (2008). Towards a model of work engagement. *Career Development International*, 13(3), 209-233.
- Bandura, A. (1977). *Social learning theory*. Englewood Cliffs: Prentice Hall.
- Bandura, A. (1986). *Social foundations of thought and action*. Englewood: Prentice Hall.
- Banerjee, G., Mitchell, J. D., Brzezinski, M., DePorre, A., & Ballard, H. A. (2023). Burnout in academic physicians. *The Permanente Journal*, 27(2), 142.
- Başar, U., Sığrı, Ü., & Nejat Basım, H. (2018). Ethics lead the way despite organizational politics. *Asian Journal of Business Ethics*, 7, 81-101.
- Brown, M. E., Treviño, L. K., & Harrison, D. A. (2005). Ethical leadership: A social learning perspective for construct development and testing. *Organizational behavior and human decision processes*, 97(2), 117-134.

- Buchanan, D. (2008). You stab my back, i 'll stab yours: management experience and perceptions of organization political behavior. *British Journal of Management*, 19(9), 49-64.
- Byrne, Z. M. (2017). All roads lead to well-being: unexpected relationships between organizational politics perceptions, employee engagement and worker well-being. *Power, Politics, and Political Skill in Job Stress.*, (15)1-32.
- Byrne, Z. S., Peters, J. M., & Weston, J. W. (2016). The struggle with employee engagement: Measures and construct clarification using five samples. *Journal of Applied Psychology*, 101(9), 1201-1227.
- Byrne, Z. S., Manning, S. G., Weston, J. W., & Hochwarter, W. A. (2017). All roads lead to well-being: Unexpected relationships between organizational politics perceptions, employee engagement, and worker well-being. In *Power, politics, and political skill in job stress* (Vol. 15, pp. 1-32). Emerald Publishing Limited.
- Chen, Q., Jiang, Q., Cifuentes-Faura, J., & Xiao, B. (2023). The invisible whirlpool in the river of organization development: the evolving process of organizational politics in China transitional economy. *Current Psychology*, 1-14.
- Chiang, Y. W.-T. (2019). Locus of control: The mediation effect between emotional stability and pro- environmental behavior. *Psychology of Sustainability and Sustainable Development*, 11(3), 795-800.
- Cropanzano, R. K. (1995). *Organizational politics, justice, and support: their differences and similarities*. Westport: Quorum Books.
- David, C., Casilli, A. A., Delanoë, A., de Rosnay, M. D., De Gelder, B., Frau-Meigs, D., ... & Chavalarias, D. (2023). *Toward a Research Agenda on Digital Media and Humanity Well-Being*, Chavalarias D. Ed..
- Den Hartog, D. (2008). Ethical and despotic leadership relationships with leader's social responsibility, top management team effectiveness and subordinates optimism a mutil-method study. *The Leadership Quarterly*, 19(3), 297-311.
- Fedor, D., Maslyn, J., Farmer, S., & Bettenhausen, K. (2008). The contribution of positive politics to the prediction of employee reactions. *Journal of Applied Social Psychology*, 38(1), 76-96.
- Ferris, G. R., & Hochwarter, W. A. (2011). *Organizational politics. A handbook of industrial and organizational psychology*. Washington DC: American Psychological Association.
- Fiedman, T. (2006). *The world is flat : A brief history of the twenty-first century*. London: Macmillan.
- Hobfoll, S. (1989). Conservation of resources: a new attempt of conceptualizing stress. *Journal of American Psychology*, 14(3), 513-524.
- Hobfoll, S. J. (2003). Resource loss, resource gain, and emotional outcomes among inner city women. *Journal of Personality and Social Psychology*, 84(3), 600-632.
- Islam, T., Ahmad, R., Ahmed, I., & Ahmer, Z. (2019). Police work-family nexus, work engagement and turnover intention: Moderating role of person-job-fit. *Policing: An International Journal*, 42(5), 739-750.
- Judge, T. A., Erez, A., Bono, J. E., & Thoresen, C. J. (2003). The core self-evaluations scale: Development of a measure. *Personnel psychology*, 56(2), 303-331.



- Kahn, W. A. (1990). Psychological Conditions of Personal Engagement and Disengagement at Work. *Academy of Management*, 33 (4), 692–724.
- Kcmar, K. A & Barron, R. A. (1999). Organizational politics: the state of field links to related processes, and an agenda for future research. *Research in Personnel and Human Resources Management*, 1(3), 1-39.
- Landells, E. M., & Albrecht, S. L. (2017). The positives and negatives of organizational politics: A qualitative study. *Journal of Business and Psychology*, 32, 41-58.
- Loi, R., Lam, L. W., & Chan, K. W. (2012). Coping with job insecurity: The role of procedural justice, ethical leadership and power distance orientation. *Journal of Business Ethics*, 108, 361-372.
- Markos, S., & Sridevi, M. S. (2010). Employee engagement: The key to improving performance. *International Journal Of Business And Management*, 5(12), 89..
- Martins, I. Y. A. M. A. B. H. O. R., Ogundare, J. T., & Akpubi, R. O. (2023). Managing Workforce Diversity And The Quest For Ethical Leadership. *International Journal of Management & Entrepreneurship Research*, 5(6), 341-359.
- Miller, V. D., Allen, M., Casey, M. K., & Johnson, J. R. (2000). Reconsidering the organizational identification questionnaire. *Management Communication Quarterly*, 13(4), 626-658.
- Rich, B. L., Lepine, J. A., & Crawford, E. R. (2010). Job engagement: Antecedents and effects on job performance. *Academy of Management Journal*, 53(3), 617-635.
- Rosander, L., & Kadefors, A. (2023). Implementing relational contracting in a public client organization: the influence of policy clashes, resources and project autonomy. *Construction Management and Economics*, 1-19.
- Rosen, C. C., & Hochwarter, W. A. (2014). Looking back and falling further behind: The moderating role of rumination on the relationship between organizational politics and employee attitudes, well-being, and performance. *Organizational Behavior and Human Decision Processes*, 124(2), 177-189.
- Rosen, C. C., Harris, K. J., & Kacmar, K. M. (2009). The emotional implications of organizational politics: A process model. *Human Relations*, 62(1), 27-57.
- Saks, A. M. (2006). Antecedents and consequences of employee engagement. *Journal Of Managerial Psychology*, 21(7), 600-619.
- Schaufeli, W. B., Bakker, A. B., & Salanova, M. (2006). The measurement of work engagement with a short questionnaire: A cross-national study. *Educational And Psychological Measurement*, 66(4), 701-716.
- Schaufeli, W. B., Taris, T. W., & Van Rhenen, W. (2008). Workaholism, burnout, and work engagement: Three of a kind or three different kinds of employee well-being?. *Applied Psychology*, 57(2), 173-203.
- Seibert, S. E., Wang, G., & Courtright, S. H. (2011). Antecedents and consequences of psychological and team empowerment in organizations: a meta-analytic review. *Journal of applied psychology*, 96(5), 981-996.
- Tyler, T. R. (1986). The psychology of leadership evaluation. In Justice in social relations (pp. 299-316). Boston, MA: Springer US.



Virgă, D., & Balan, G. (2023). Grit as a mediator between core self-evaluations and mental health complaints: The moderating role of workload. *Psihologia Resurselor Umane*, 21(1)-35-48.

Witt, L. A., Kacmar, K. M., Carlson, D. S., & Zivnuska, S. (2002). Interactive effects of personality and organizational politics on contextual performance. *Journal of Organizational Behavior: The International Journal of Industrial, Occupational and Organizational Psychology and Behavior*, 23(8), 911-926.

Yukl, G. A., & Latham, G. P. (1978). Interrelationships among employee participation, individual differences, goal difficulty, goal acceptance, goal instrumentality, and performance. *Personnel Psychology*, 31(2), 305-323.

Zainun, N. A. (2020). Machiavellianism, locus of control, moral identity, and ethical leadership among service sector leaders in Malaysia: the moderating effect of ethical role modelling. *International Journal of Sociology And Social Policy*, 41(9), 1108-1133.